



#### ASIC/1-8655 Features

- Sequences include:
  - 1& 2 Stage Heat Pumps
  - Up to 4 Stage Air Conditioners
- 8 Form C (NO,NC) relay outputs with isolated return.
- 2 Analog Outputs 0-10 Vdc
- 2-Part Screw Terminals
- Compatible with WS-051 Digital Wall Sensor
- Other Features include:
  - Modulating Economizer
  - CO<sub>2</sub> Demand Ventilation
  - Auxiliary Heating / Cooling
  - Lighting Control
  - Changeover Analog Output
- Compatible with ASI WebLink & ASI Data Server Products

The ASIC/1-8655 is a pre-programmed digital controller for use in the control of Packaged Air Conditioner units for both new construction and retrofit applications. This controller maintains the space temperature by turning on and off stages of heating or cooling. The controller has personalities for one and two stage heat pumps and up to four stage air conditioning units.

The controller monitors zone temperature through the WS-0X1 Wall Sensor. It calculates the cooling or heating requirement for the space based upon comparing this temperature with the cooling and heating setpoints. The WS-051 Digital Display Wall Sensor can be used with this controller. Control of the indoor fan is included. It also has optional auxiliary cooling and auxiliary electric or gas heat. The optional modulating economizer can be based on discharge air or mixed air temperature. The optional changeover analog output can be used for hydronic heating or cooling.

The ASIC/1-8655 controls compressors, and electric or gas heat. An optional modulating-economizer is controlled as the first stage of cooling. It has 8 N.O./N.C. relays with isolated return, so that no interposing relays are necessary. It has two analog outputs, 0 to 10 Vdc, 5 mA, that can be assigned to heating, cooling, modulating economizer, or changeover heating/cooling. The controller is mounted on a steel base, and has an optional steel top cover.

No user programming or calibration is necessary. The pre-configured controller allows newly installed zones to be started up quickly and efficiently. A pre-tuned PI algorithm means that controllers can accurately maintain space temperature.

The controllers include after-hours override, and user temperature adjustment. Afterhours usage is automatically stored at each unit. Time-based features such as scheduled changes in setpoints may be used when the controller is connected in a network that can synchronize the ASIC/1 internal software clock by broadcasting a time message.

The ASIC/1-8655 can operate stand alone or as part of a larger communicating control network with other ASI controllers. Communication at speeds up to 19,200 baud means rapid access to information. This enables integrated control of the complete mechanical system to ensure optimum building performance. Temperatures, setpoints, and other controller information may be easily reported to ASI WebLink, or any Windows based software that is a client for OLE for Process Control (OPC).

The ASIC/1-8655 has flash programming. The firmware can be upgraded over the local RS-485 communications bus.

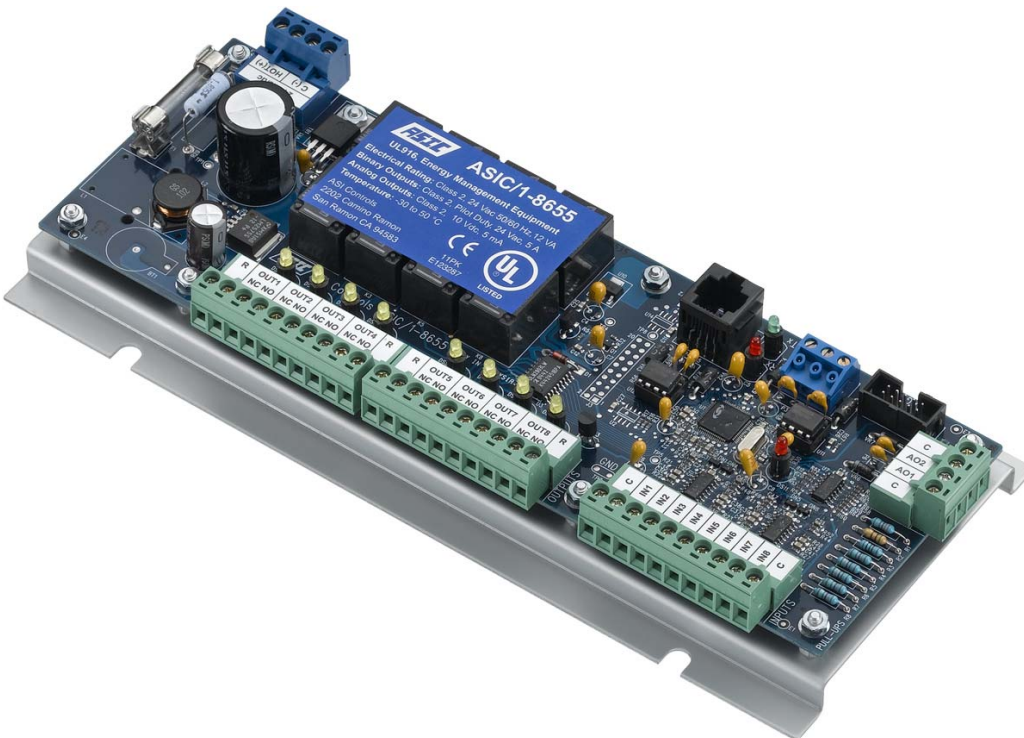



### Specifications

#### Control Power

Supply Voltage: 24 Vac/Vdc +/- 15%, 50/60 Hz,  
 Power Consumption: 12 VA (plus loads)  
 Fuse: 2 A.

#### Outputs 10

Binary Output: 8 Form C Relays, NO/NC  
 24 Vac, 5 A, Pilot Duty  
 2 groups of 4 outputs with  
 common return

Analog Output: 2, 0-10 Vdc, 5 mA, 8 bit.

#### Inputs 8

Type: Universal Analog/Binary  
 Range: 0 to 5 Vdc  
 Resolution: 10 bit, 0.1% full scale  
 Accuracy: 1 %  
 Temperature Sensor: WS-0X1  
 3 kohm at 77 °F (25 °C) thermistor

#### Communications

Format: RS-485 1/2 duplex  
 Protection: 100 mA polyswitch fuse, TVS  
 Baud Rate: up to 19,200 baud  
 Repeater: ASI Converter/Repeater  
 every 32 devices

#### Connections

Power and I/O: 2 part screw terminals  
 Communications: 3 Position screw terminals  
 Zone Sensor: 8 position, modular jack,  
 for use with ASI cable, SCP-0XX

#### Other

Indication: LEDs, 1 Power,  
 8 Output, 2 RS-485  
 Dimensions: 3.25" x 9.50" x 1.50"  
 83 mm x 241 mm x 38 mm  
 Steel Base: 4.5" x 9.7" x 0.70" (WxLxH)  
 114 mm x 246 mm x 18 mm  
 with mounting holes on center  
 6.7" x 3.95" (170 mm x 100 mm )  
 Weight with base: 1.34 lb (0.61 kg)

#### Environmental

Operating: -22 to +122 °F (-30 to 50 °C)  
 10 to 95% rh non-condensing  
 Storage: -40 to +167 °F (-40 to 75 °C)  
 5 to 95% rh non-condensing

#### UL Listing & CE

Rated as a Class 2 Device, Pilot Duty

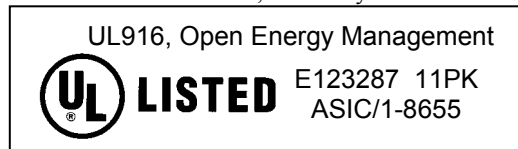

Meets CE requirements.

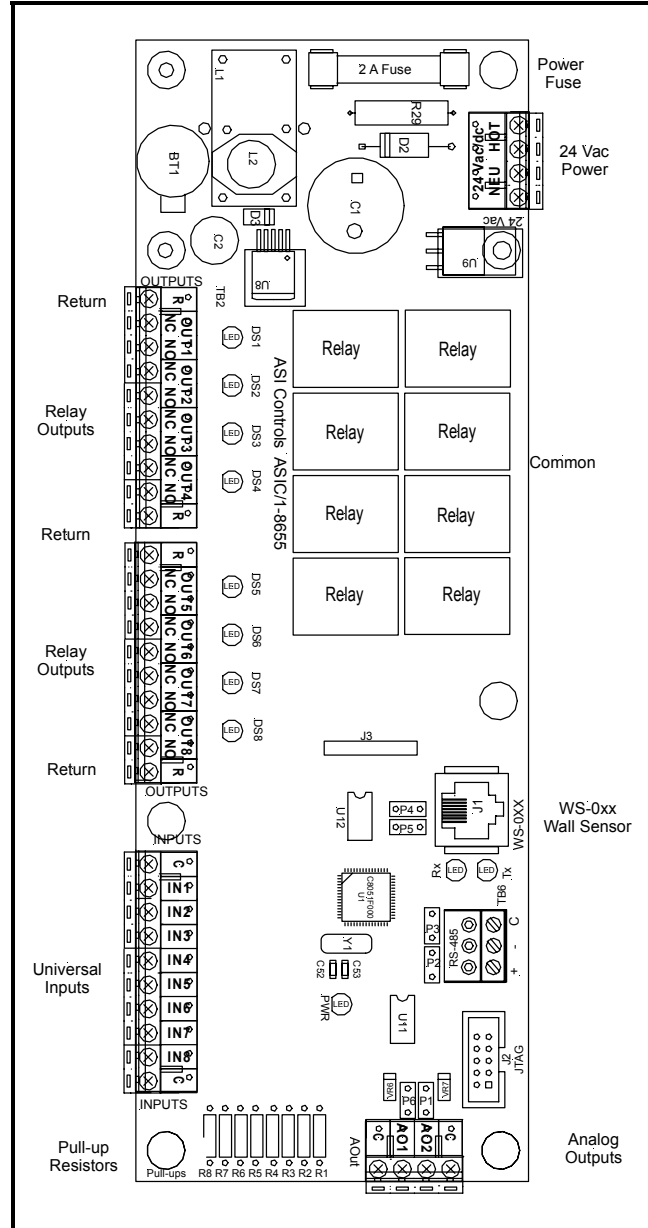

How to Order:	Order Number
Packaged AC Controller	ASIC/1-8655

Accessories:	Order Number
Wall Temperature Sensor	WS-0XX
Sensor Cable	SCP-0XX
Top Cover Kit	CE-8655

Software & Documentation:	Order Number
ASI Expert Configuration Software	ASI Expert
ASIC/1-8655 User Manual	8655 Manual